

FLARE NUT WRENCH

No.	S (Hexagonal shaped)	L			
MZ1-10	10	160	80	5	

- Fastening/loosening brake pipe flare nuts of mini, compact & medium sized cars of all car makers.
- 45° angled & straight ends for wider application.

● **FLARE NUT WRENCH (MZ1)**

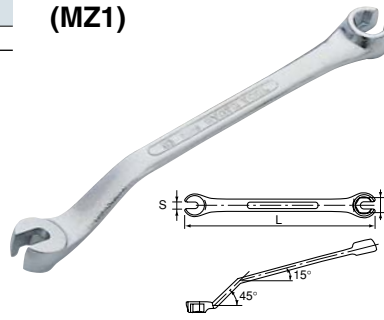

Replacing inner parts
③ Disassembling of the Pipe

4

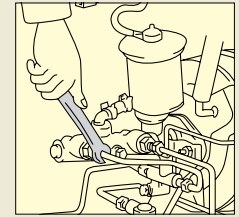

FLARE NUT WRENCH

No.	S ₁ (Hexagonal shaped) × S ₂ (Hexagonal shaped)	L			
MZ1-10 × 12	10 × 12	160	80	5	
-11 × 12	11 × 12	160	80	5	
-10 × 14	10 × 14	165	100	5	

- Fastening/loosening brake pipe flare nuts of mini, compact & medium sized cars of all car makers.
- 45° angled & straight ends for wider application.

● **FLARE NUT WRENCH (MZ1-10×12)**

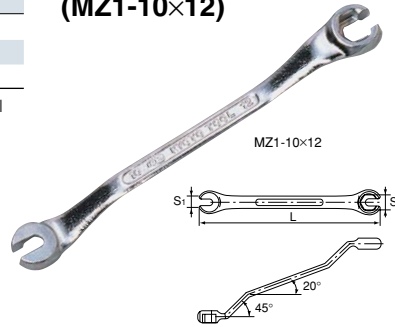

FLARE NUT WRENCH

No.	S ₁ × S ₂	L			
MZ10-10 × 12	10 × 12	145	80	5	
-14 × 17	14 × 17	164	100	5	

- Special wrench for removing/attaching brake pipe flare nuts and clutch pipe flare nuts (hydraulic type).
- Contacting by 5 points for turning nuts securely.

POWERFIT (MZ10-10 × 12 only)

● **FLARE NUT WRENCH (MZ10)**

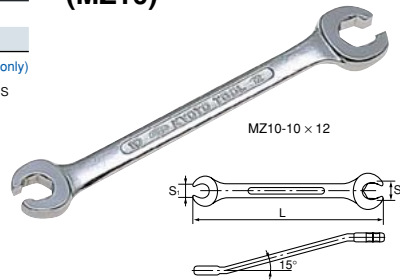

FLARE NUT WRENCH·SET (2pcs.)

No. MZ112	135	10		
Flare Nut Wrench	MZ11-10, 12			

No.	S ₁ × S ₂ (Hexagonal shaped)	L			
MZ11-10	10 × 10	150	60	10	
-12	12 × 12	154	75	10	

- Combination of Flare Nut Wrench and Open End Wrench.
- Open end for quick turning and split-ring end for final tightening.

● **FLARE NUT WRENCH & SET (MZ11 2pcs.)**



● **INTERNAL SNAPPING PLIERS**



P.134

● **OTHER TOOLS**

④ Disassembling Master Cylinder