

ELECTRIC SYSTEM

Removing/Installing Thermo-sensor and Oxygen Sensor

1 Removing/Installing Thermo-sensor and Oxygen Sensor



●3/8"sq. THERMO-SENSOR SOCKET

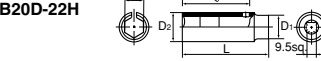
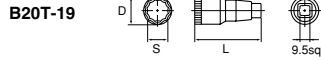

THERMO-SENSOR SOCKET · O₂ SENSOR SOCKET

No. B202TD	▼g 290	📦 1
Thermo-Sensor Socket 19mm	B20T-19	
O ₂ Sensor Socket 22mm	B20D-22H	

CAUTION • FOR CHECKING AND CHANGING THERMO-SENSOR AND O₂ SENSOR.

THERMO-SENSOR SOCKET

No.	S	D	L	▼g	📦
B20T-19	19	26	73	55	1

Purpose • Specially designed in accordance with the size shape of thermo-sensor.
Application • For Toyota, Nissan, Mazda and Daihatsu cars.
Special features • Thin wall type with small diameter for using in narrow engine rooms.

CAUTION • DO NOT USE THIS SOCKET FOR ANY PURPOSE, EXCEPT FOR REMOVING/INSTALLING THERMO-SENSORS.

O₂ SENSOR SOCKET

No.	S (6pt.)	D ₁	D ₂	ℓ	L	▼g	📦
B20D-22H	22	27	30	70	90	235	1

Purpose • For removing/installing O₂ sensor.
Application • Deep socket with slit for easy operation.

Special features • Specially designed in accordance with the size and shape of O₂ sensor.
 • With 3/8" square female drive for using with ratchet handles or extension bars.

CAUTION • DO NOT USE FOR ANY PURPOSE OTHER THAN REMOVING/ATTACHING A O₂ SENSOR.



ELECTRIC SYSTEM

Removing/Installing Oil Pressure SW

1 Removing/Installing Oil Pressure SW

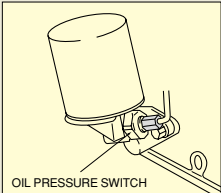

●3/8"sq. OIL PRESSURE SOCKET · SET (2pcs.)

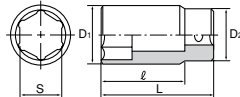

OIL PRESSURE SOCKET · SET (2pcs.)

No. B202HD	▼g 470	📦 1
Oil Pressure Socket	B20-24HD,27HD	

No.	S (6pt.)	D ₁	D ₂	ℓ	L	▼g	📦
B20-24HD	24	32.5	28.5	46	58	230	1
-26HD	26	35	30	46	58	230	1
-27HD	27	36.5	31	46	58	240	1

Purpose • For removing/installing oil pressure switch.
Special features • With 3/8" square female drive for easy operation.

ELECTRIC SYSTEM

Battery replacement

Removing vehicle batteries



This tool is great for removing batteries from hard to reach areas. There is a rubber pad on the gripping part of the tool to prevent scratching the battery.

●BATTERY CATCHER

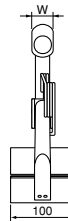
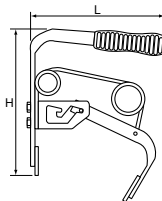
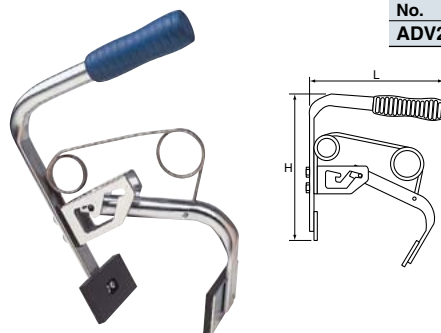

BATTERY CATCHER

No.	L	W	H	▼kg	📦
ADV2	193	33	215	0.95	1

Usage • Useful in battery removal and carrying
Application • From light weight vehicles to passenger and one-box car batteries.
 • Battery width 120~180mm, Less than 22kg in mass. (Sample battery size: JIS26A17RL~95D31RL)
 * Replacement grips are available. Check with your dealer or service provider for details.