

# SA Series MODEL SA-VI

available shanks 対応シャンク

- HSK BT STT ST MT JT

available functions 対応機能

- compression 縮み tension 伸び depth control 寸止 radial float 調芯 self-reverse 逆転 coolant クーラント

- ◎ Designed for wide range of machine tools
- Synchro error compensation on tension and compression
- Short design for limited space
- Quick-change of tap collets

◎あらゆる機械に使用できる

- 伸縮機構により同期誤差を吸収
- 狭い空間用の短身タイプ
- タップコレットをすばやく交換!

combination chart 組み合わせ表	matching collets P17 推奨コレット P17
SA 412-VI	TC 412
SA1022-VI	TC1022

## model ST-SA-VI (cylindrical parallel shank)

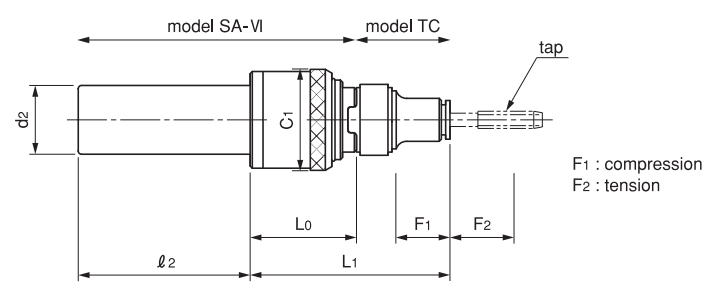

unit:mm

model	L0	L1	C1	F1	F2	ST shank		capacity	weight (kg)
						ℓ2	d2		
☆ ST20-SA 412-VI	93.0	49.5	47	6	8	60	20	M3~M16	0.51
ST25-SA 412-VI	93.0	49.5	47	6	8	75	25	M3~M16	0.64
ST32-SA 412-VI	93.0	49.5	47	6	8	80	32	M3~M16	0.86
ST32-SA1022-VI	140.0	75.0	64	8	10	80	32	M8~M27	1.47
☆ ST42-SA1022-VI	140.0	75.0	64	8	10	80	42	M8~M27	1.80

※Models marked with ☆ may require a longer delivery term because they are based on per-order production.  
 ※☆の型は受注生産のため納期までに時間がかかる場合があります。ご了承下さい。

## model STT-SA-VI (Flatted cylindrical parallel shank for CNC lathes)

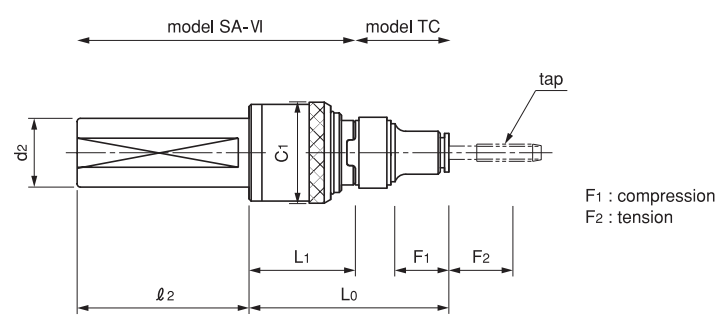

unit:mm

model	L0	L1	C1	F1	F2	STT shank		capacity	weight (kg)
						ℓ2	d2		
STT20-SA 412-VI	93.0	49.5	47	6	8	60	20	M3~M16	0.51
STT25-SA 412-VI	93.0	49.5	47	6	8	75	25	M3~M16	0.64
STT32-SA 412-VI	93.0	49.5	47	6	8	80	32	M3~M16	0.86
STT32-SA1022-VI	140.0	75.0	64	8	10	80	32	M8~M27	1.47
☆ STT40-SA1022-VI	140.0	75.0	64	8	10	80	40	M8~M27	1.73

※Models marked with ☆ may require a longer delivery term because they are based on per-order production.  
 ※☆の型は受注生産のため納期までに時間がかかる場合があります。ご了承下さい。



ST32-SA412-VI + TC412



STT32-SA412-VI + TC412